

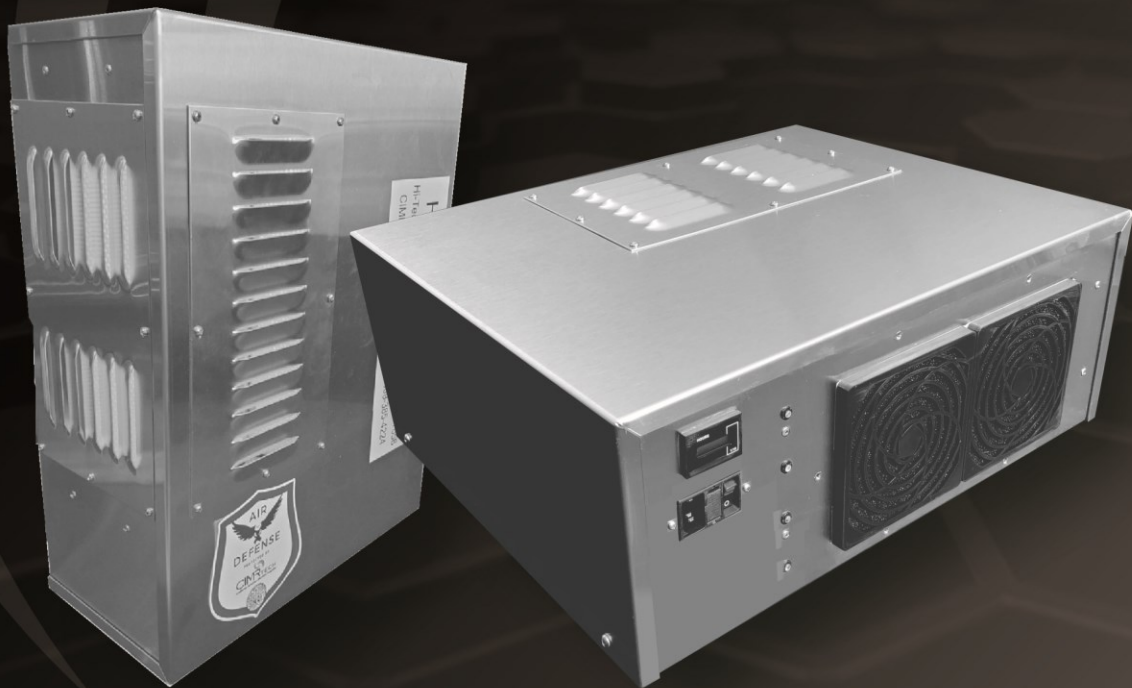

CIMR® 414



EQUIPMENT MANUAL

Active Air and Surface Pathogen Scavenging Technology



CONTENTS	PAGE
SECTION 1	3
HOW CAN...	3
CIMR®'S CAPABILITIES	3
CIMR®'S CREDENTIALS	4
CIMR®'S COMPLIANCE	4
CIMR®'S CUSTOMERS	5
SECTION 2	5
DESCRIPTION AND TYPE	5
FACILITIES AND APPLICATIONS	5
DIMENSIONS	6
SPECIFICATIONS	6
FEATURES	6
OPERATIONS	7
GENERAL MAINTENANCE	8
CHANGING THE CIMR® CELL	8
TROUBLE SHOOTING	9
WARRANTY	11



CONTINUOUS INFECTIOUS MICROBIAL REDUCTION (CIMR®)
Active Air and Surface Pathogen Scavenging Technology
A Unique and Proprietary Solution

SECTION 1

HOW CAN...

- People safely occupy shared indoor air spaces?
- Indoor air and surfaces be sanitized effectively to ensure a healthy environment?
- We combat and eliminate the transmission/spreading of pathogens (viruses, bacteria, fungi, and molds).
- We be protected from future variations and mutations 24/7/365.

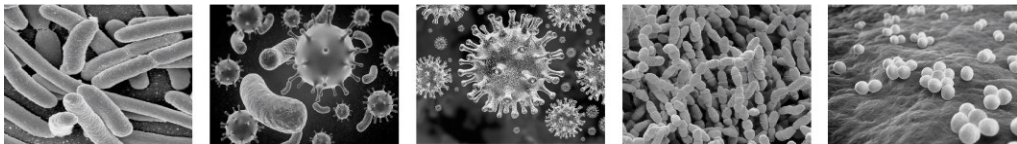

CIMR®'S CAPABILITIES

- CIMR®'s Air Infusion Technology is designed specifically to kill airborne and surface pathogens.
- CIMR® is an ultra-low level, safe and effective Hydrogen Peroxide-based air and surface disinfectant system that produces zero ozone.
- Hydrogen Peroxide (water and oxygen) actively targets and deactivates both aerosolized and surface pathogens in enclosed spaces.
- CIMR® produces 0.02 ppm (parts per million) of Hydrogen Peroxide at 1/50th of OSHA (Occupational Safety and Health and Administration) limits.

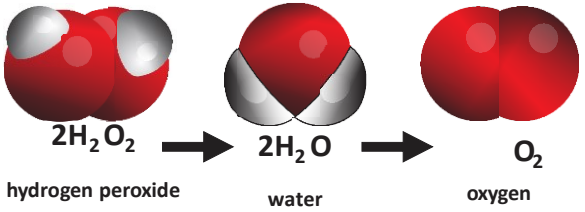

- CIMR® continuously purifies the air much faster than other systems and chemicals.
- CIMR® is military-grade technology and scientifically proven through numerous independent lab tests.
- CIMR® eliminates up to 99.9% pathogens.
- Similar levels of Hydrogen Peroxide are present in the outside air.

CIMR[®]'S CREDENTIALS

- CIMR[®] was developed in 2004 by Alton Holt while working with the US Army Corps of Engineers, US Army and US Navy.
- CIMR[®]-TECH, a division of HI-TECH, is the only designer, developer, and supplier of CIMR[®] Technology, equipment and programs.
- HI-TECH provides customized engineering design systems and services based on decades of experience, independent testing and scientific reviews.
- Hundreds of military facilities have been and are using CIMR[®] with thousands of units installed worldwide.
- CIMR[®] was tested, in accordance with national and international standards as required by regulatory authorities.
- CIMR[®] is registered, and verified by accredited, and independent authorities, and scientific labs.



CIMR[®]'S COMPLIANCE

- CIMR[®] was independently tested, is safe and has no adverse effects on metal, wood, fabric, and electronic equipment.
- CIMR[®] is FDA (Food Drug Administration) compliant.
- CIMR[®] carries the CARB (California Air Resources Board) certifying ZERO ozone emissions.



- CIMR[®] meets and exceeds EPA (Environmental Protection Agency), OSHA (Occupational Safety and Health Administration), CDC (Center for Disease Control) and the WHO (World Health Organization) Regulations in Air and Surface Disinfection standards.
- CIMR[®] technology and equipment has achieved various certifications, registrations, compliance seals, and stamps of approval.





CIMR®'S CUSTOMERS

- The United States Military, US Army Corps of Engineers, FEMA (Federal Emergency Management Agency),
- State and County facilities, United State Department of Homeland Security, and National Historical Society.
- Universities, schools and colleges such as Lamar University, Beaumont, Texas, Texas Educational Systems and Houston Baptist University.
- Hospitals, clinics, doctor's offices and senior care homes.
- Entertainment venues, corporate offices, oil and gas drilling, hotel and leisure facilities.
- Shelters, food production and processing facilities, places of worship, churches and homes.

SECTION 2

DESCRIPTION AND TYPE

- Designed to provide air and surface sanitization for large scale commercial and industrial applications and buildings.
- It has the ability to sanitize environments with heavy microbial growth.
- Ideal for treating high traffic areas
- Largest portable indoor air and surface sanitizing, disinfecting, and purification unit.
- Sanitizes larger environments with challenging situations.
- Can be used as a plug-in, stand-alone and/or wall mounted unit or be installed directly into the HVAC ductwork/air conditioning systems.
- Discreet or concealed installation.
- Military grade stainless steel.
- Low maintenance.

FACILITIES AND APPLICATIONS

- A single CIMR® 414 unit can sanitize up to 16,000 square feet.
- Multiple units may be used for larger or more challenging environments.
- Large spaces include:
 - Commercial and large residential buildings
 - Auditoriums, theaters, entertainment and exhibition centers
 - Government and county buildings.
 - Hospitals, clinics, nursing homes and assisted living centers.
 - Universities, colleges and schools.
 - Cafeterias, restaurants, food processing and preparation facilities.
 - Gyms, fitness centers, hotels, airports, churches and places of worship.
 - Large residential buildings.
 - Remediation and under construction sites.



CAUTION!

Switch of the CIMR® unit, disconnect it from the wall plug or power source and disconnect the power cable before servicing.

DIMENSIONS

Unit:	19.25 L x 15 H x 7.25 W inches 48.90 x 38.1 x 18.42 cm
Boxed:	21 L x 18 W x 9 H inches 53.34 L x 45.72 W x 22.86 H cm
Weight:	30 lbs./13.06 kg

SPECIFICATIONS

Electrical:	120V or 240V AC 50/60 HZ
Mechanical:	Dual fans 4 x 14 inch/35.56 cm CIMR® cells/4 x UV lights/2 x filters
Power usage:	130 Watts or less
Coverage:	16,000 square foot/1,487 square meters
Please note:	Square foot/meters capacity and sizing is based on 8 - 10 foot/2.44 – 3.05 meters ceiling heights.

The CIMR® 414 is a UV device governed by the following requirements:

- FIFRA 40 CFR 152.500 and 156.10
- FIFRA 41FR 51065
- EPA 065975-TN-001

FEATURES

- Fixed mounted or portable and anti-theft mounting is available.
- Low power consumption and no hard wiring is required.
- Plugs into existing electrical outlets, wall plug or a converter plug.
- UV lights have a 1-year warranty with a 3-year life expectancy.
- 110-volt models use a 1.6-amp slow blow fuse.
- Adjustable between 1,000 to 16,000 square feet
- Internal fan system if used as portable stand-alone unit.

OPERATIONS

- The fan switch is on/off. No adjustment is required.
- If you shut off the HVAC system for maintenance, turn the CIMR® unit off and turn it back on when regular operation resumes.

FRONT VIEW

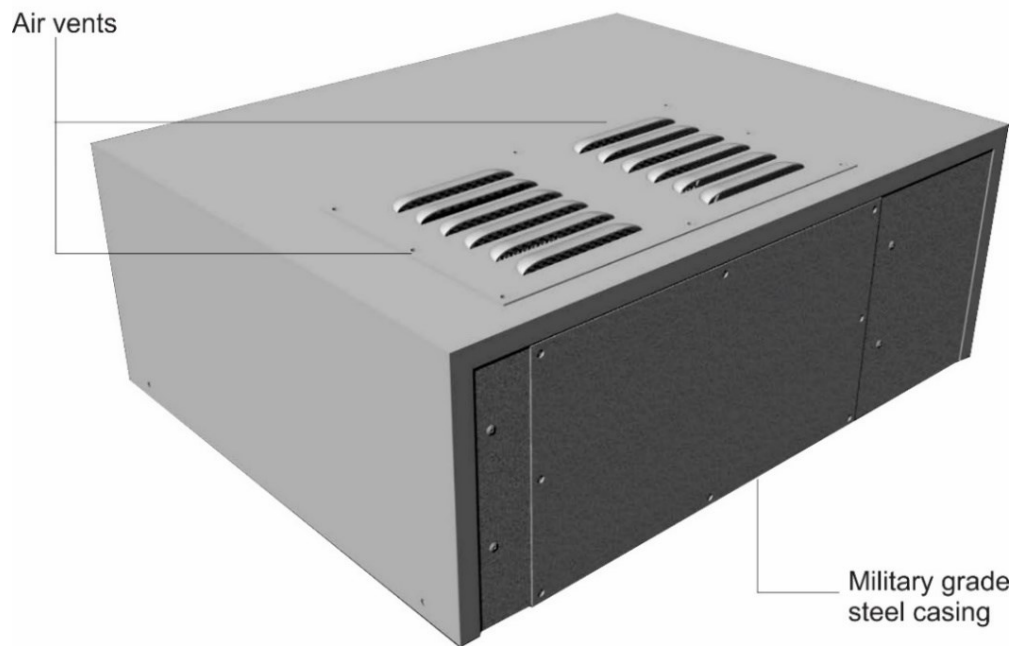

BACK VIEW

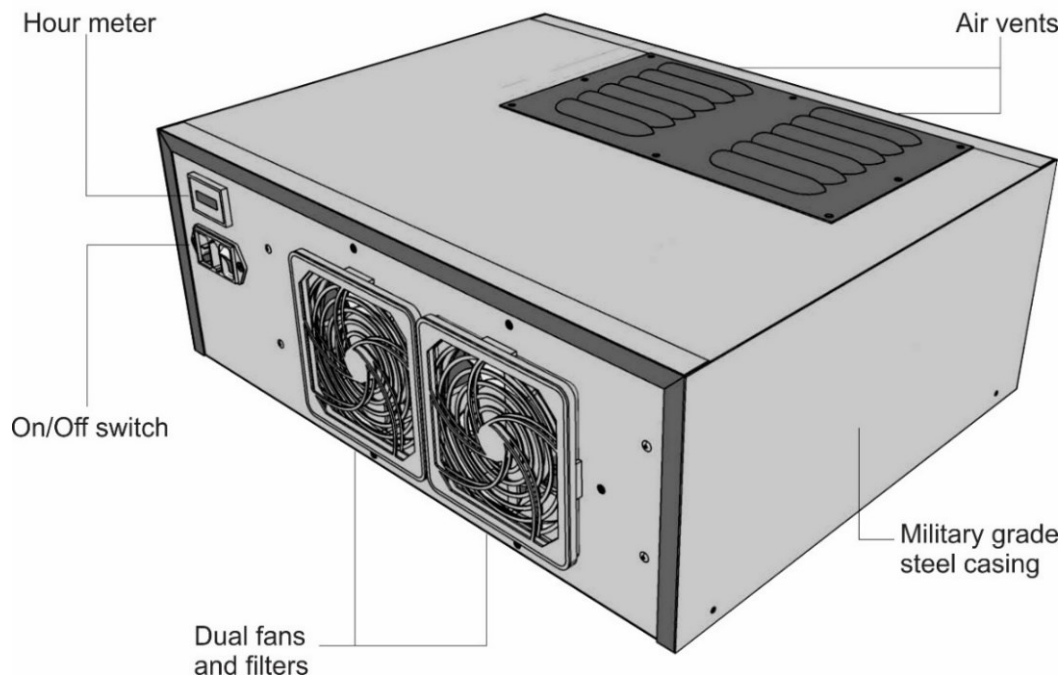

GENERAL MAINTENANCE

- Periodic maintenance is required to ensure that your CIMR[®] 414 unit is working correctly.
- If you are operating your unit in a severely polluted and dirty environment, cleaning the unit and inspecting the rear filter should be performed frequently.
- The case can be wipe down with a soft cloth dampened (not wet) with water or mild detergent.
- The CIMR[®] cells are to be carefully vacuumed.
- Do not wash the CIMR[®] cells as damage will occur.
- The rear filter can be taken out and washed, and put back into the unit.
- The filter can also be cleaned by using a typical hairdryer.
- NOTE: If a paper filter such as HEPA or regular air filter is installed, replace the filter.

CHANGING THE CIMR[®] CELL

- The CIMR[®] cells should be replaced every 2-3 (two to three) years depending on the environment.
- The warranty on the unit is 5 (five) years and on the CIMR[®] cells 1 (one) year.
- If the CIMR[®] cells are to be removed, please contact Hi-Tech for guidance.

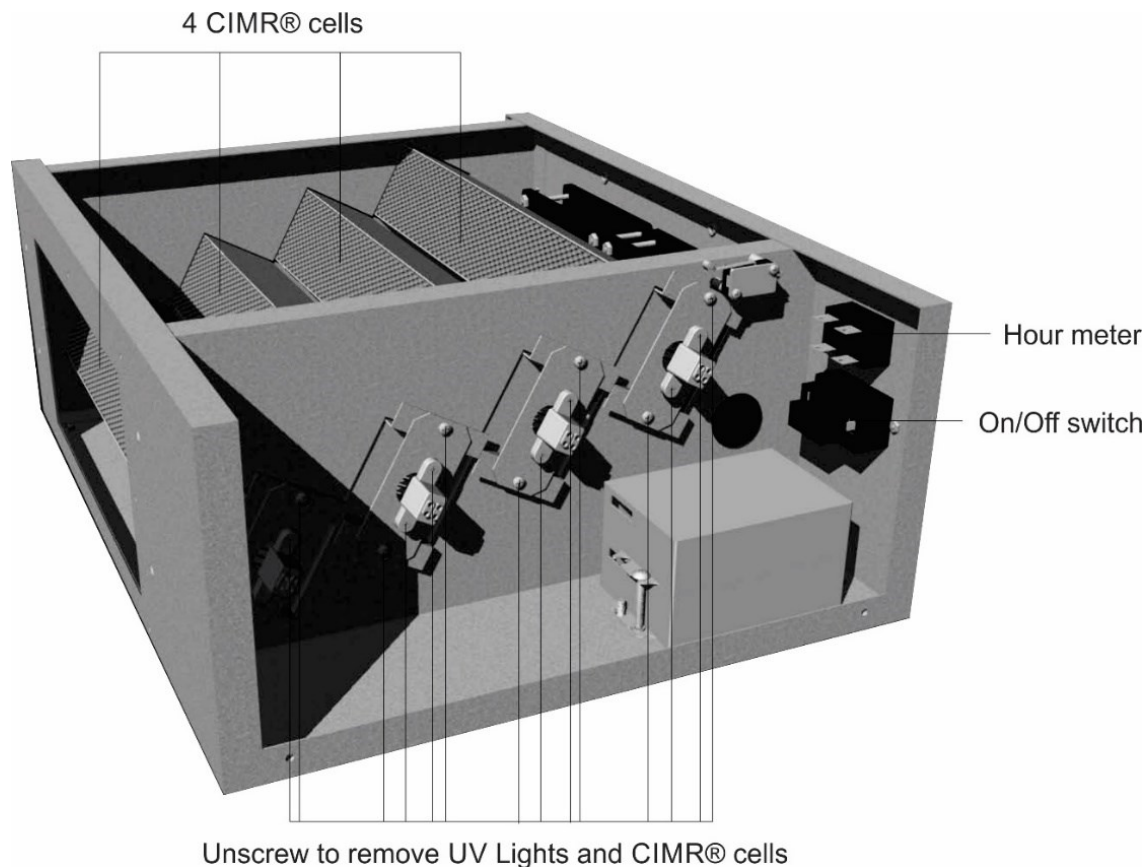

4 CIMR® cells

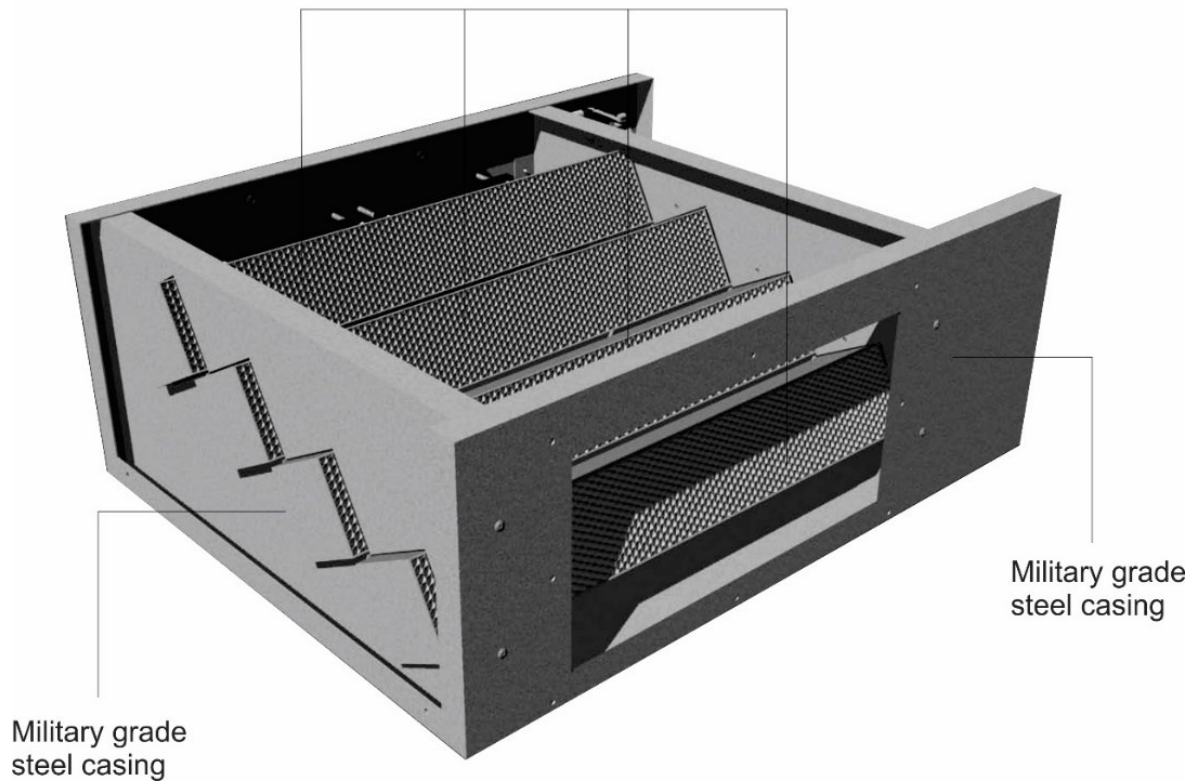

TROUBLE SHOOTING

What to look for first if the unit is not working:

- Make sure the power cord is inserted entirely into the receptacle at the back of the CIMR® 414 unit.
- Make sure the electrical cord is plugged into the electrical outlet or wall plug.
- Make sure the outlet or wall plug is capable of providing power to the unit.
- Make sure to turn the unit on.



CAUTION!

- **Do not look directly at the glowing UV light.**
- **According to the American Conference of Governmental Industrial Hygienists standards, prolonged exposure, even to reflected UV light, can cause eye damage.**
- **CIMR® emits UV light which can cause eye damage if the light were looked at continuously (for 20 minutes or longer) at a distance of one (1) inch/two point 5 (2.5) cm or less.**

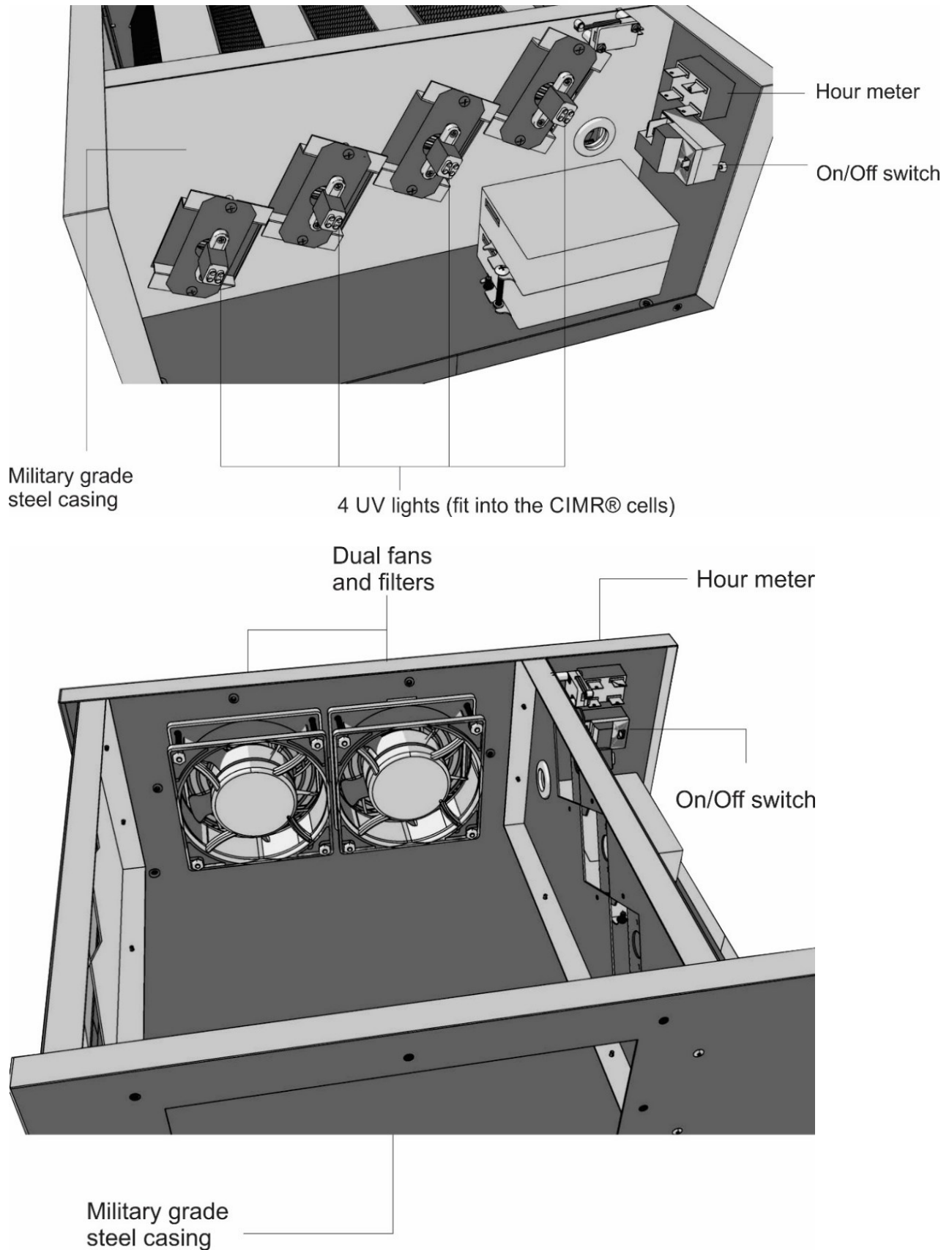



WARRANTY

- The CIMR® unit must be connected to a UPS power supply to maintain a smooth and clean, reliable 110/120 V AC power supply (serving as a conditioner) to be covered under this warranty.
- For international installations, if the CIMR® 414 unit requires a 220/240V AC power supply, the unit must be connected to both a step-down transformer and a UPS power supply to maintain a smooth and clean, reliable 110/120 V AC power supply (serving as a conditioner) to be covered under this warranty.
- Hi-Tech equipment liability under this warranty shall be limited to repair, or at Hi-Tech's option, replacement without charge, excluding transportation and shipping.
- All transportation and shipping costs or charges on parts or units submitted under this warranty shall be borne by the purchaser unless agreed to by Hi-Tech in writing.
- Hi-Tech can either perform the repairs and/or replacement in accordance with the warranty at our worksite or at the location where installed.
- Any unit/s returned for repair after the warranty period or show damage, for which Hi-Tech is not responsible for, will be repaired at a reasonable charge.
- Hi-Tech will advise the customer of the cost before proceeding with any repairs.
- Under its sole discretion, Hi-Tech will not warranty the unit if subjected to improper voltage, alteration, misuse, negligence, accident, or damage, and unauthorized service.
- Do not attempt to disassemble the unit without contacting Hi-Tech, as this will void the warranty.

Warranty issued by:

CIMR-TECH

A division of HI-TECH Air & Water Purification, LLC.

Lamar University-CICE

5091 Rolfe Christopher, Suite 213

Beaumont, TX 77705

info@cimrtech.com

(866) 231-3687 Option #2

CIMR® is the solution.

CIMR® protects lives, businesses and economies.

CIMR® is the way forward!

END